

DO NOT OPEN THIS TEST BOOKLET UNTIL YOU ARE ASKED TO DO SO**TEST BOOKLET SERIES****TEST BOOKLET
LECT. (ECE) T.E. 2016****C**

Time Allowed : 2 Hours]

[Maximum Marks : 100

*All questions carry equal marks.***INSTRUCTIONS**

1. Immediately after the commencement of the examination, you should check that test booklet does not have any unprinted or torn or missing pages or items, etc. If so, get it replaced by a complete test booklet.
 2. **Encode clearly the test booklet series A, B, C or D as the case may be in the appropriate place in the answer sheet.**
 3. Write your Roll Number only in the box provided alongside.
Do not write anything else on the Test Booklet.
 4. This Test Booklet contains 100 items (questions). Each item comprises four responses (answers). Choose only one response for each item which you consider the best.
 5. After the candidate has read each item in the Test Booklet and decided which of the given responses is correct or the best, he has to mark the circle containing the letter of the selected response by blackening it completely with Black or Blue ball pen. In the following example, response "C" is so marked :
- Ⓐ
Ⓑ
●
Ⓓ
6. Do the encoding carefully as given in the illustrations. While encoding your particulars or marking the answers on answer sheet, you should blacken the circle corresponding to the choice in full and no part of the circle should be left unfilled. After the response has been marked in the ANSWER SHEET, no erasing/fluid is allowed.
 7. You have to mark all your responses ONLY on the ANSWER SHEET separately given according to 'INSTRUCTIONS FOR CANDIDATES' already supplied to you. Responses marked on the Test Booklet or in any paper other than the answer sheet shall not be examined.
 8. All items carry equal marks. Attempt all items. Your total marks will depend only on the number of correct responses marked by you in the Answer Sheet. There will be no negative marking.
 9. Before you proceed to mark responses in the Answer Sheet fill in the particulars in the front portion of the Answer Sheet as per the instructions sent to you.
 10. If a candidate give more than one answer, it will be treated as a wrong answer even if one of the given answers happens to be correct.
 11. After you have completed the test, hand over the Answer Sheet only, to the Invigilator.

DO NOT OPEN THIS TEST BOOKLET UNTIL YOU ARE ASKED TO DO SO

P.T.O.

Time Allowed : 2 Hours]

[Maximum Marks : 100

1. The difference between BCD-to-decimal decoder and BCD-7-segment decoder is that :

- I. In BCD-to-7 segment decoder, each output is activated for more than one combination of inputs.
- II. BCD-to-7 segment activates a unique pattern of outputs for each combination of inputs.

- (A) Only (I) is true
- (B) Only (II) is true
- (C) Both (I) and (II) are true
- (D) Both (I) and (II) are false

2. In 74138 (3-line-to-8-line) decoder, Enable inputs are used to :

- I. Enable the IC
- II. Expand the size of decode
- III. Convert decoder into DEMUX

- (A) Only (I) and (II) are true
- (B) Only (I) and (III) are true
- (C) Only (II) and (III) are true
- (D) All are true

3. The fastest logic family is :
- (A) TTL (B) IIL
(C) ECL (D) Schottky TTL
4. The A/D converter with minimum delay is :
- (A) Dual Slope ADC
(B) Flash ADC
(C) Successive approximation ADC
(D) Digital ramp ADC
5. AND-OR-implementation is equivalent to :
- (A) NOR-AND Implementation
(B) NOR-NOR Implementation
(C) NAND-NAND Implementation
(D) OR-NAND Implementation

6. The band gap of silicon at room temperature is :
- (A) 0.7 eV (B) 1.1 eV
(C) 1.4 eV (D) None of these
7. A silicon p-n junction is forward biased with a constant current at room temperature. When temperature is increased by 10°C , the forward bias voltage across the p-n junction :
- (A) Increases by 60 mV (B) Decreases by 60 mV
(C) Increases by 25 mV (D) Decreases by 25 mV
8. The action of a JFET in its equivalent circuit can be best be represented as a :
- (A) Current controlled current source
(B) Voltage controlled voltage source
(C) Voltage controlled current source
(D) Current controlled voltage source

9. Sub-threshold operation in MOSFET occurs in :
- (A) strong inversion region (B) weak inversion region
- (C) saturation region (D) cut-off region
10. For an n-channel enhancement type MOSFET, if the source is connected at higher potential than that of the bulk, the threshold voltage of the MOSFET will :
- (A) Increase (B) Remain unchanged
- (C) Decrease (D) None of these
11. Which of the following is *correct* regarding Mesh analysis ?
- (A) It is applicable to planar networks
- (B) It is applicable to non-planar networks
- (C) It is applicable to both planar and non-planar networks
- (D) None of the above

12. The condition of reciprocity for a passive linear two-port network in terms of ABCD parameters can be described as :
- (A) $A = D$ (B) $AD - BC = 1$
(C) $A = C$ (D) $AC - BD = 1$
13. Order of complexity of a network is specified by :
- (A) number of independent state variables
(B) number of independent first order differential equations
(C) number of independent initial conditions
(D) All of the above
14. The following parameters may be selected as state variables for writing state equations of networks :
- (A) Capacitor Current and Inductor Voltage
(B) Capacitor Current and Inductor Flux
(C) Capacitor Charge and Inductor Current
(D) Capacitor Charge and Inductor Flux

15. For the 2-port network shown, the Y_{21} parameter is found to be :

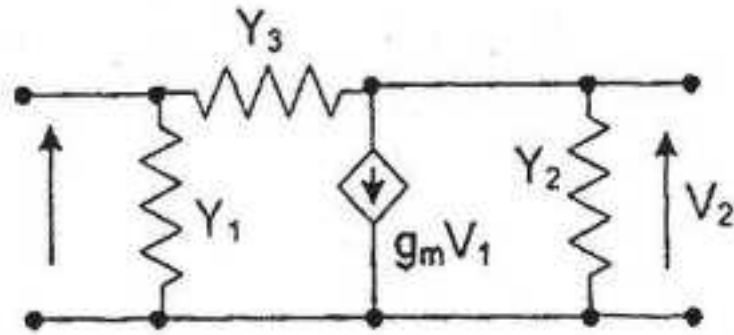

(A) $Y_2 + Y_3$

(B) $g_m - Y_3$

(C) $Y_3 - g_m$

(D) $g_m + Y_2 + Y_3$

16. Which is the longest instruction of 8085 microprocessor ?

(A) CALL address

(B) JMP address

(C) RST 5

(D) STA address

17. What is the address space of 8085 microprocessor ?

(A) 64 Kbytes

(B) 32 Kbytes

(C) 16 Kbytes

(D) 8 Kbytes

18. What is the benefit of multiplexing an address/data bus in 8085 microprocessor ?
- (A) Speed improvement
 - (B) Pin count reduction
 - (C) Reduction in additional hardware requirement
 - (D) None of the above
19. How many memory locations can be addressed by a microprocessor with 14 address lines ?
- (A) 16 Kbytes
 - (B) 32 Kbytes
 - (C) 64 Kbytes
 - (D) 14 Kbytes
20. What can be the maximum size of the stack in an 8085 microprocessor ?
- (A) 8 K
 - (B) 16 K
 - (C) Size of the RAM
 - (D) Size of ROM and RAM

21. For a hertz dipole antenna, the half power beam width in the E-plane is :

(A) 45°

(B) 90°

(C) 180°

(D) None of these

22. A medium wave radio transmitter operating at a wavelength of 492 m has a tower antenna of height 124 m. What is the radiation resistance of the antenna ?

(A) 73Ω

(B) 36.5Ω

(C) 100Ω

(D) 50Ω

23. The Brewster angle for a parallel-polarized wave travelling from air into glass for which $\epsilon_r = 5.0$ is :

(A) $\tan^{-1}(5.0)$

(B) $\tan^{-1}(\sqrt{5.0})$

(C) $\sin^{-1}(5.0)$

(D) $\sin^{-1}(\sqrt{5.0})$

24. At $f = 2$ GHz a material has $\sigma = 25$ S/m, relative permittivity $\epsilon_r = 80$. At this f , the material acts as :

- (A) Insulator (B) Conductor
(C) Perfect dielectric (D) None of these

25. If the electric field of a plane wave in free space is :

$$E(z, t) = 10^3 \sin(\omega t - \beta z) \bar{a}_y \text{ V/m}$$

The magnetic field intensity of the plane wave is :

- (A) $\bar{H}(z, t) = -10^3 \sin(\omega t - \beta z) \bar{a}_x \text{ A/m}$
(B) $\bar{H}(z, t) = 10^3 \sin(\omega t - \beta z) \bar{a}_x \text{ A/m}$
(C) $\bar{H}(z, t) = \frac{10^3}{120\pi} \sin(\omega t - \beta z) \bar{a}_x \text{ A/m}$
(D) $\bar{H}(z, t) = \frac{-10^3}{120\pi} \sin(\omega t - \beta z) \bar{a}_x \text{ A/m}$

26. The wavelength of a wave having propagation constant $\gamma = 3 + j0.1\pi$ rad/m is :

- (A) 10 m (B) 30 m
(C) 20 m (D) 25 m

27. Which one of the fundamental equation was modified by Maxwell to form the basis of electromagnetic theory ?

- (A) Gauss law of electrostatic (B) Faraday law
(C) Coulomb law (D) Ampere circuital law

28. The fundamental period of the signal

$$x[n] = e^{-jn\pi/16} \cos(n\pi/17)$$

is :

- (A) 17 (B) 34
(C) 1088 (D) 544

29. Let $h[n]$ be the unit sample response of a lowpass filter with cut-off frequency ω_c . A filter with unit sample response,

$$g[n] = (-1)^n h[n]$$

is :

- (A) Lowpass (B) Bandpass
(C) Highpass (D) Allpass

30. The system, with unit sample response

$$h[n] = 2^n u[n] + 3 \left(\frac{1}{2}\right)^n u[n],$$

in z -plane has :

- (A) a zero at $13/8$ (B) zeros only at origin
(C) poles at $1/2$ and $13/2$ (D) no finite pole

31. The inverse z -transform of

$$X(z) = \frac{1}{(1 - 0.4z^{-1})^2} \quad |z| > 0.4,$$

is :

- (A) $(n+1)(0.4)^n u[n]$ (B) $(n+1)(0.4)^{-n} u[-n-1]$
(C) $n(0.4)^n u[n]$ (D) $n(0.4)^{-n} u[-n-1]$

32. An accumulator is described by the following difference equation

$$y[n] = \sum_{k=-\infty}^n x[k], \text{ where } x[n] \text{ is the input and } y[n] \text{ is the output sequence.}$$

If this system is excited by the $x[n] = nu[n]$ and $y[-1] = 0$, the output $y[n]$, will be given by :

- (A) n (B) n^2
(C) $n(n+1)$ (D) $n(n+1)/2$

33. A system is described by the following differential equation, where $u(t)$ (unity step function) is input to the system and $y(t)$ is the output of the system

$$\frac{dy(t)}{dt} + 5y(t) = u(t).$$

When $y(0) = 1$ and $u(t)$ is a unit step function, $y(t)$ is :

- (A) $0.2 + 0.8e^{-5t}$ (B) $0.2 - 0.2e^{-5t}$
(C) $0.8 + 0.2e^{-5t}$ (D) $0.8 - 0.8e^{-5t}$
34. A continuous, linear time-invariant filter has an impulse response $h(t)$ described by :

$$h(t) = \begin{cases} 3, & 0 \leq t \leq 3 \\ 0, & \text{otherwise} \end{cases}$$

When a constant input of value 5 is applied to this filter, the steady state output is :

- (A) 9 (B) 15
(C) 45 (D) can't be determined

35. The impulse response of a continuous time system is given by :

$$h(t) = \delta(t - 1) + \delta(t - 3).$$

The value of the step response at $t = 2$ is :

- (A) 0 (B) 1
(C) 2 (D) 3
36. Let $x(t) = \cos(10\pi t) + \cos(30\pi t)$ be sampled at 20 Hz and reconstructed using an ideal lowpass filter with cut-off frequency of 20 Hz. The frequency/frequencies present in the reconstructed signal is/are :

- (A) 5 Hz and 15 Hz only
(B) 10 Hz and 15 Hz only
(C) 5 Hz, 10 Hz and 15 Hz only
(D) 5 Hz only

37. A stable linear time invariant (LTI) system has a transfer function

$$H(s) = \frac{1}{s^2 + s - 6}.$$

To make this system causal it needs to be cascaded with

another LTI system having a transfer function $H_1(s)$. A correct choice for $H_1(s)$ among the following options is :

- (A) $s + 3$ (B) $s - 2$
(C) $s - 6$ (D) $s + 1$

38. The electric field due to an infinite sheet of charge :
- (A) varies inversely with distance
 - (B) is constant
 - (C) is zero
 - (D) varies inversely with square of distance
39. The force on a loop of wire of radius ' d ' and carrying current ' I ', in a uniform magnetic field ' B ' is :
- (A) $\mu I d B$
 - (B) $\mu I^2 d B$
 - (C) zero
 - (D) $\mu I^2 B / d$
40. The force on a charge ' q ' placed at origin, due to a Magnetic field ' B ' is given by (' E ' is the Electric field, and ' v ' is potential) :
- (A) $F = qE$
 - (B) $F = qB$
 - (C) $F = qv \times B$
 - (D) zero

41. A fixed length source coding scheme is :
- (A) Huffman coding (B) Shannon-Fano coding
- (C) Lempel Ziv coding (D) Arithmetic coding
42. A source generates three independent symbols with probabilities 0.25, 0.25, 0.50 at a rate of 3000 symbols per second. The most efficient source encoder would have average bitrate (bits/sec) :
- (A) 6000 (B) 4500
- (C) 3000 (D) 1500
43. A non-linear modulation scheme is :
- (A) ASK (B) PSK
- (C) FSK (D) QAM
44. To transmit 10 Mbps data using 16 QAM, minimum bandwidth required will be :
- (A) 2.5 MHz (B) 1 MHz
- (C) 3 MHz (D) 0.625 MHz

45. A communication channel with AWGN operating at an SNR $\gg 1$ and bandwidth B has capacity C_1 . If the SNR is double keeping B constant, the resulting capacity C_2 is approximately given by :

(A) $2 C_1$

(B) $C_1 + B$

(C) $C_1 + 2 B$

(D) $C_1 + 0.3 B$

46. In a GSM system, 8 channels can coexist in 200 kHz bandwidth using TDMA. An operator is allocated 5 MHz bandwidth. Assuming a 5 cell reuse pattern, the maximum number of simultaneous channels that can exist in one cell is :

(A) 200

(B) 40

(C) 25

(D) 5

47. On account of the effect of inductance in pressure coil, the dynamometer type Wattmeter at leading power factor tends to read :

(A) Low

(B) High

(C) Erratically

(D) Normally

48. A load cell is a :
- (A) Strain gauge (B) Photovoltaic cell
(C) Thermistor (D) Pressure pick up
49. The resolution of a digital ammeter with 4-digit display is :
- (A) $1/10000$ (B) $1/1000$
(C) $1/4$ (D) $1/2$
50. The dielectric constant of a material may be measured by :
- (A) Maxwell's bridge (B) Schering's bridge
(C) Hay's bridge (D) Anderson's bridge
51. An inscription in Chamba town is dated 1717 Vikrami Samvat. Roughly what would be the corresponding year in Saka Samvat ?
- (A) 1582 (B) 1592
(C) 1602 (D) 1612

52. When did the famous Mandi conspiracy take place under the influence of Ghader Party ?
- (A) 1909-10 (B) 1911-12
(C) 1912-13 (D) 1914-15
53. In which District of H.P. there has been no change in the density of population between 2001 and 2011 AD ?
- (A) Kinnaur (B) Chamba
(C) Lahul-Spiti (D) Kullu
54. In which District of H.P. is Dera Baba Bharbhag Singh ?
- (A) Hamirpur (B) Bilaspur
(C) Una (D) Kangra
55. When was the title of raja conferred on the Jagirdar of Lambagraon ?
- (A) 1870 AD (B) 1889 AD
(C) 1909 AD (D) 1919 AD

56. In which district of H.P. is Bhrigu Lake ?
- (A) Kullu (B) Lahul-Spiti
(C) Chamba (D) Kinnaur
57. In which month of Vikrami Samvat is Cherwal festival celebrated ?
- (A) Jyeshtha (B) Asadh
(C) Shrawan (D) Bhadon
58. At which place in Kullu District is the HPMC upgrading its packing house ?
- (A) Out (B) Patlikuhal
(C) Katrain (D) Bajaura
59. In what ratio is the cost of Swan river Integrated Watershed Project is being shared as loan and as state share ?
- (A) 70 : 30 (B) 80 : 20
(C) 85 : 15 (D) 90 : 10

60. In which river basin is Gaj Hydel Project ?
- (A) Ravi (B) Beas
(C) Satluj (D) Giri
61. What is the name of the Trust with which Salman Khurshid and Louise are associated ?
- (A) Maulana Azad Memorial Trust
(B) Zakir Hussain Memorial Trust
(C) Fakhruddin Ali Ahemad Memorial Trust
(D) Humayun Kabir Memorial Trust
62. Which student organization was banned by IIT Madras around May, 2015 ?
- (A) Democratic Youth Federation of India
(B) Revolutionary Students Organization
(C) Ambedkar-Periyar Study Circle
(D) PMK

63. According to UN's Report by the FAO released in Rome in May, 2015 which country has the highest number of under-nourished people in the world ?
- (A) China (B) Pakistan
(C) India (D) Bangladesh
64. With which game is Ritu Rani associated ?
- (A) Badminton (B) Tennis
(C) Cricket (D) Hockey
65. For which dance form is Leela Samson known ?
- (A) Kathakali (B) Kathak
(C) Bharat Natyam (D) Kuchipudi
66. To which political party does Recep Tayyip Ergogan, President of Turkey belong ?
- (A) Justice and Development Party
(B) Republican People's Party
(C) Nationalist Movement Party
(D) Peoples Democratic Party

67. In which country is Kruen, where G-7 Summit was held in June, 2015 ?

(A) Belgium

(B) Switzerland

(C) Germany

(D) Poland

68. Who is Prayuth Chan-Ocha ?

(A) Ruler of Thailand

(B) Football player of Korea

(C) Writer of China

(D) Pop singer of Vietnam

69. Where are Nansha Islands ?

(A) Arabian Sea

(B) Bay of Bengal

(C) Red Sea

(D) South China Sea

70. In World Economic Forum's Global **Gender** Gap Report which country is in position number one (minimum **gap**) ?

(A) Iceland

(B) Norway

(C) Finland

(D) None of these

71. An earth station receiver consists of :
- (A) RF to IF down converter (B) IF to RF converter
 (C) Either (A) or (B) (D) None of these
72. The improvement achieved in the signal to noise ratio if one bit is increased in a PCM system is :
- (A) 6 dB (B) 3 dB
 (C) 12 dB (D) None of these
73. A signal is transmitted through a 10 km coaxial line channel which exhibits a loss of 2 dB/km. If the transmitted signal power is -30 dBW, determine the output of a receiver amplifier which has a gain of 15 dB.
- (A) -50 dB (B) -65 dB
 (C) -35 dB (D) -5 dB
74. Condition to avoid slope overloading distortion in delta modulation can be reduced by :
- (A) Increasing the stepsize
 (B) Increasing the sampling frequency
 (C) Both (A) and (B)
 (D) None of the above

75. The maximum opening of eye for transmission over bandlimited channel corresponds to :
- (A) Optimum sampling instant
 - (B) Minimum distortion instance
 - (C) Minimum error instance
 - (D) All of the above
76. A system has 14 poles and 2 zeros. The slope of its highest frequency asymptote in its magnitude plot is :
- (A) -40 dB/dec
 - (B) -240 dB/dec
 - (C) -280 dB/dec
 - (D) $+40$ dB/dec
77. To detect the error between a reference shaft position and an output shaft position which of the following error detectors can be used ?
- (A) A pair of tachogenerators
 - (B) A pair of potentiometers
 - (C) A pair of synchros
 - (D) All of these

78. The derivative control improves :

- (A) Transient response
- (B) Steady-state response
- (C) Both transient and steady-state response
- (D) None of the above

79. For the open-loop transfer function of a system,

$$G(s)H(s) = \frac{K}{s(s+2)(s+4)(s+6)}$$

the centroid of the root-locus is located at :

- (A) -1
- (B) -2
- (C) -3
- (D) -4

80. The open-loop transfer function of a control system has one pole in the RHS-plane and its Nyquist plot encircles $-1+j0$ point twice in the clockwise direction, then the system is :

- (A) Unstable
- (B) Stable
- (C) Critically stable
- (D) Conditionally stable

81. The ideal input and output impedances of a current amplifier are respectively :
- (A) infinite and zero (B) zero and infinite
(C) zero and zero (D) infinite and infinite
82. A simple current mirror using BJT with $\beta = 100$ exhibits a current transfer error of :
- (A) 0.5% (B) 1%
(C) 2% (D) 4%
83. An inverting Schmitt trigger uses a $10 \text{ k}\Omega$ resistor in positive feedback loop. If the feedback factor is 0.6, what is the value of other resistor in the circuit ?
- (A) $25 \text{ k}\Omega$ (B) $20 \text{ k}\Omega$
(C) $15 \text{ k}\Omega$ (D) $5 \text{ k}\Omega$
84. Maximum theoretical efficiency in class B amplifiers is :
- (A) 25% (B) 50%
(C) 78% (D) 100%

85. Second order notch filter can be realized by adding the following filter responses :
- (A) band-pass and all-pass (B) band-pass and low-pass
(C) band-pass and high-pass (D) none of these
86. As the pole-Q of a biquadratic filter is increased, the poles :
- (A) move away from imaginary axis
(B) move close to imaginary axis
(C) remain unchanged
(D) cannot predict
87. The zero(s) of a second order band-pass filter lie at :
- (A) origin (B) infinity
(C) both origin and infinity (D) centre frequency
88. Which of the following blocks comprise a PLL ?
- (A) VCO (B) Phase detector
(C) LPF (D) All of these

89. A MOS transistor can be used as a VVR in :

(A) saturation region

(B) triode region

(C) either of the two

(D) none of the two

90. If an inverting amplifier is used as a block in realizing an oscillator, then the feedback network must ensure a phase shift of :

(A) 180°

(B) 90°

(C) 0°

(D) none of these

91. Address/data bus is demultiplexed using :

(A) Ready

(B) IO/M

(C) ALE

(D) HOLD

92. When MVI A, 00H is executed, the following flags are affected :

(A) Zero

(B) Carry

(C) Auxiliary Carry

(D) None of these

93. Which one of the following interrupts works with edge and level triggering (both) but is also maskable ?
- (A) RST 4.5 (B) RST 5.5
(C) RST 6.5 (D) RST 7.5
94. Maximum number of devices that can be connected using I/O Mapped I/O addressing are :
- (A) 128 (B) 256
(C) 512 (D) 64
95. If the last address of a memory of size 4K is 3FFFH, then the address of the first location would be :
- (A) 3000H (B) 3100H
(C) 3800H (D) 2FFFH
96. A Darlington emitter-follower circuit is sometimes used in output stage of a TTL gate in order to :
- (A) increase its I_{OL}
(B) reduce its I_{OH}
(C) increase its speed of operation
(D) reduce power dissipation

97. 8-bit 2's complement representation of a decimal number is 11100000. What is the number ?
- (A) -224 (B) -1
(C) -32 (D) 224
98. In 2's complement, subtract -2 from 6. The number will be :
- (A) -8 (B) +8
(C) +4 (D) -4
99. The number of distinct Boolean Expressions or Boolean Functions of 2 variables is :
- (A) 2 (B) 4
(C) 8 (D) 16
100. The minimum number of NOR gate required to implement the function $F = A + AB' + AB'C$ is :
- (A) 1 (B) 2
(C) 3 (D) 0